



Mould Screen Installation Manual

Protected by US Patent # 5,443,923

Your mouldscreens are packaged as fully assembled – ready to use – products. To ensure the maximum life span and optimum performance of your ScatterGuard, care must be taken when mounting and aligning the magnets.

Installation:

Step #1 Place the magnets on the mold frame making sure they are parallel to the parting line on both the front and back halves. Make sure the magnets are centered vertically. The horizontal center lines of the magnets must also be parallel to both the top and bottom of the mold frame. See diagram 1

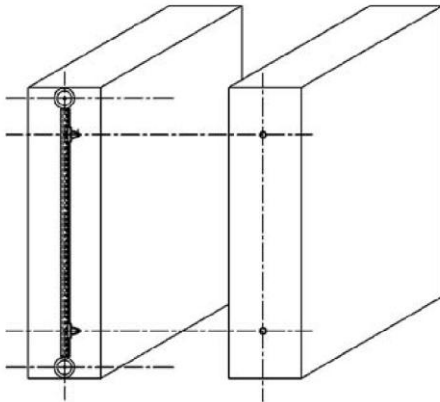

Scatterguard mounting diagram #1
Vertical & Horizontal Center Lines
must be parallel for longest life.

Step #2 To install mouldscreen out of the box and without change to the assembled items see diagram 2. Care should be taken to locate magnets as specified in step 1 above.

Step #3 An alternative method of mounting your mouldscreen allows you to extend the shield below the mold frame in increments of 76.2, 101.6, or to a maximum of 127 mm. This is achieved by using the optional extension bracket and spacer which can be purchased with your shield. Part number BKT-2

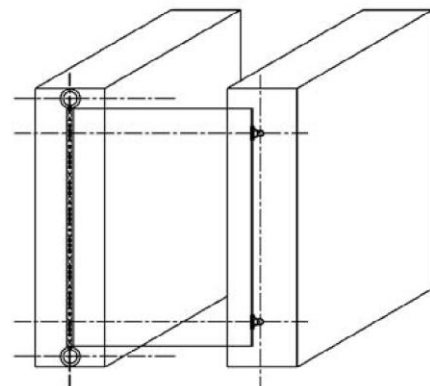

Scatterguard mounting diagram #2
Vertical & Horizontal Center Lines
must be parallel for longest life.

The maximum recommended temperature for ScatterGuard is 250 F or 121 C

To extend the shield below the mold frame, remove both magnets from their magnet posts. On the top magnet insert the supplied spacer between the magnet post and the magnet. Reattach the magnet to its post. At the bottom of the shield insert the magnet post extension bracket to the magnet post. Select which position you want to use for your application, either 76.2, 101.6, or 127 mm, and attach the magnet to the magnet post extension. Care should be taken to locate magnets as specified in step 1 above. However the extension bracket must be rotated slightly so that the head of the screw in the magnet on the top of the bracket is not touching the shield material.

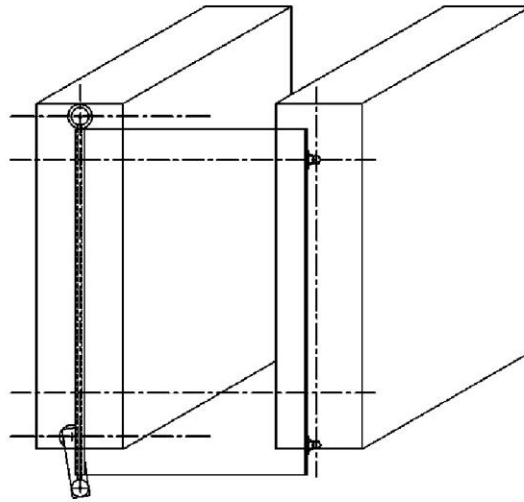

Scatterguard mounting diagram #3

Use this mounting to install Scatterguard below bottom of mold frame
Vertical & Horizontal Center Lines must be parallel for longest life.
Rotate extension bar to move screw head from under shield.

WARNINGS:

If the mold is opened causing the mouldscreen to come off the shaft between the magnet posts it can be easily reattached. Simply remove one of the magnet posts and slide the shield back onto the rod. Reattach the magnet post to the magnet making sure both magnets are on the same plane. See note 1 above.

Sharp objects and or flames will destroy your shield.

SG1 (200) and SG2 (300)

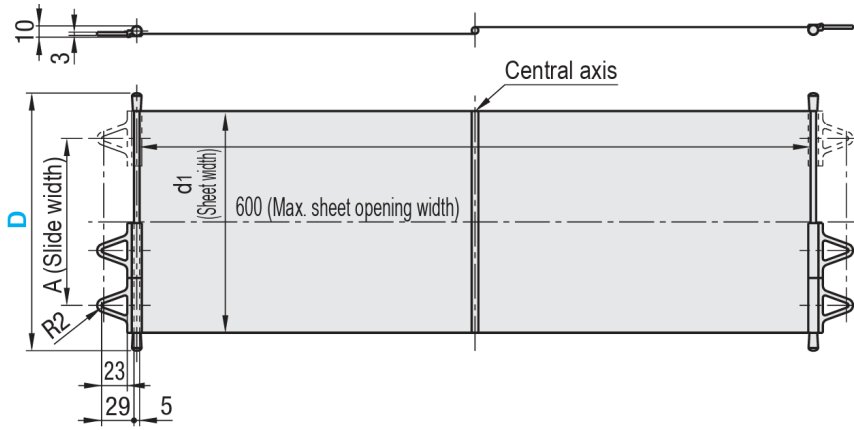

SG3 (400), SG4 (500) and SG5 (600)

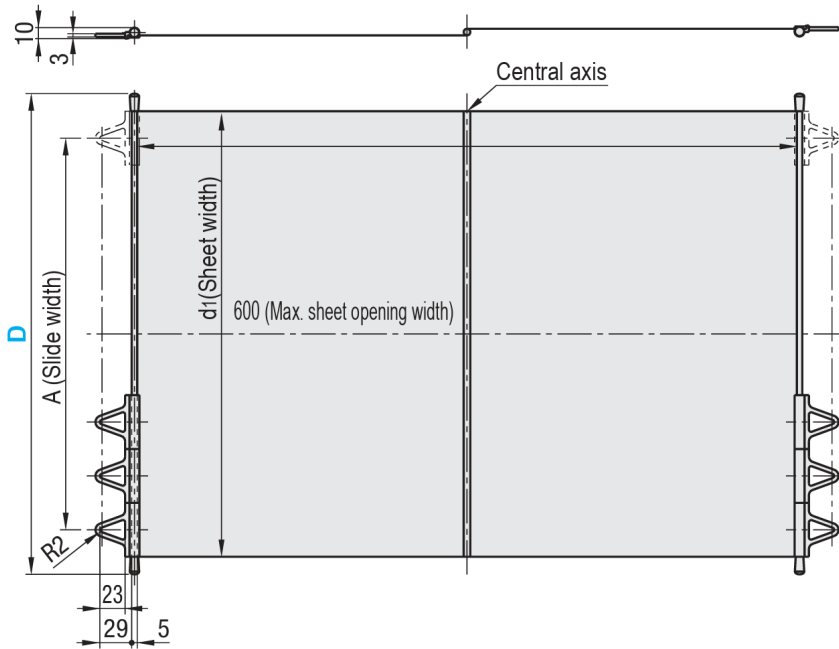

A	d1	No. of magnet (pcs)	Part Number	
			Type	D
149	198	8	SG-1	200
280	295		SG-2	300
380	395	12	SG-3	400
480	495		SG-4	500
580	595		SG-5	600

MOULDPRO APS – BALTORPBAKKEN 10 – DK2750 BALLERUP DENMARK

Tel: + 45 7020 3131

www.mouldpro .com email sales@mouldpro.com